

Mobile Banking Solution



 **Finacle**
from
Infosys®

Win in the flat world

BUSINESS OVERVIEW

With mobile devices becoming integral to people's lives, banks are seeking to leverage the ubiquity of mobile phones to create a cost-effective virtual distribution channel, rapidly innovate, extend reach across segments and improve convenience and security of use. Adoption of this new channel for value-based transactions remains limited, as there are several consumer concerns around the security of the channel. Additionally, the diversity of hand held devices presents a unique challenge for banks seeking to optimize services delivery across the gamut of devices and customer segments.

A truly secure mobile banking solution built on open standards, for increased agility and flexibility, can prove invaluable for banks. Support for services delivery through SMS and GPRS/WAP enabled handsets, is a clear mandate. The solution must also intuitively address the hurdles posed by multiplicity of form factors and access mechanisms, in the mobile space.

FINACLE MOBILE BANKING SOLUTION

Finacle mobile banking solution empowers retail and corporate banking customers with access to banking services through SMS and GPRS/WAP-enabled handsets, leveraging a single platform. It offers both mobile commerce and mobile payments within the DNA of mobile banking, with built-in support for merchant-initiated payments and reversals, in addition to customer-initiated payments and reversals. Leveraging recent technological advances in the mobility space, the solution empowers banks with the means to innovate by easily deploying new services, with improved time to market. The end user experience thus created is richer, secure and truly convenient.

Finacle mobile banking solution functions in tandem with disparate host systems, core banking solutions, payment networks and third-party applications. The solution is interfaced with Infosys MConnect, the indigenously developed middleware, which orchestrates mobile transactions between users' devices and the Finacle universal banking solution. Infosys MConnect handles the multiplicity of form factors and access mechanisms on multiple devices to provide a context-adaptable view to the transaction server. This presents banks with a powerful channel to service customer segments ranging from the mass affluent to the under-banked or unbanked, surmounting the challenge posed by the diversity of mobile devices.

The solution supports synchronization of customers' own data on their mobiles without re-downloading the application for downloadable client-based mobility. It empowers banks to capitalize on their existing Internet transaction and support capabilities to extend it to the mobile world, in practically real time. This ushers in the advantages of reduced integration by leveraging common interface messages, maintenance and deployment costs.

FUNCTIONAL ARCHITECTURE

Mobile Banking Solution

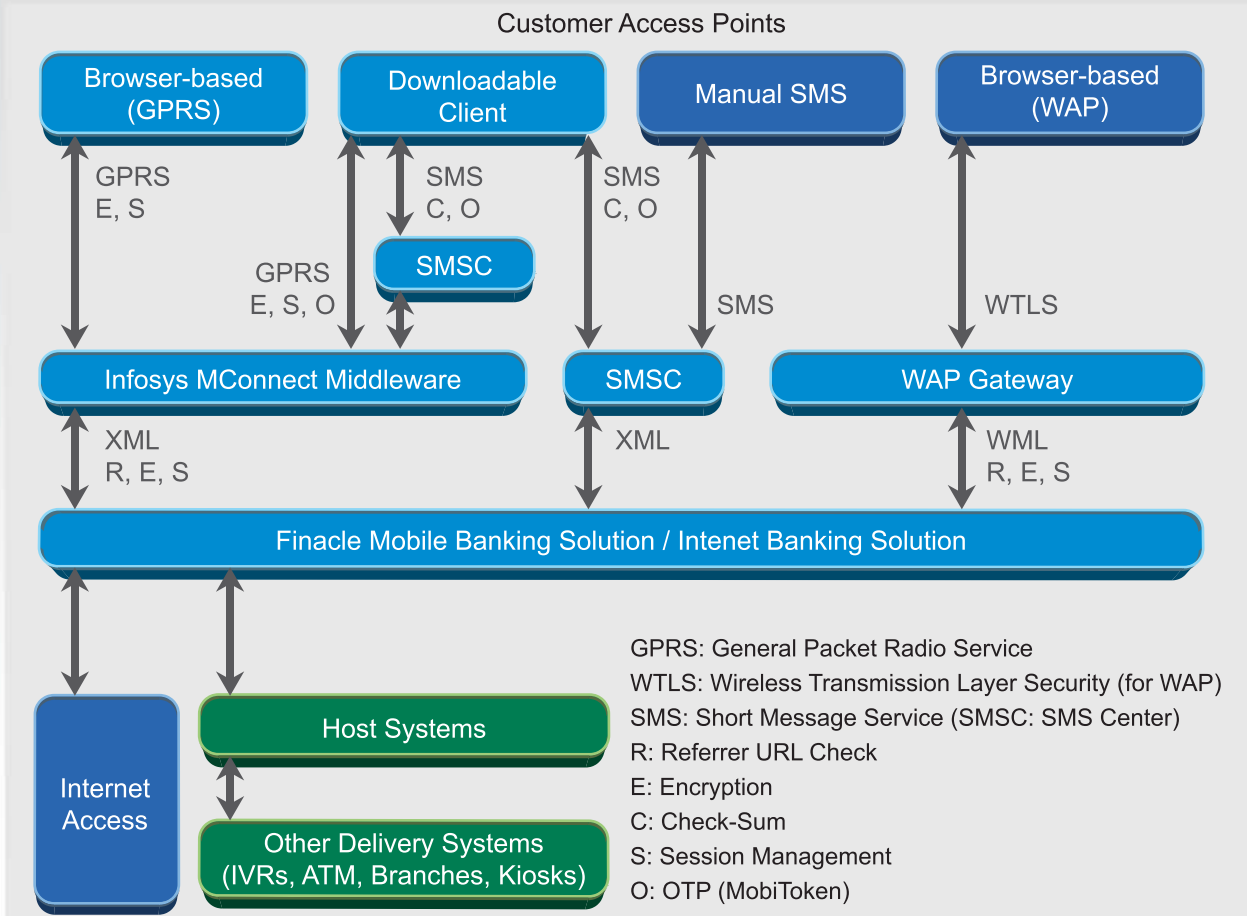

Universal Banking Solution

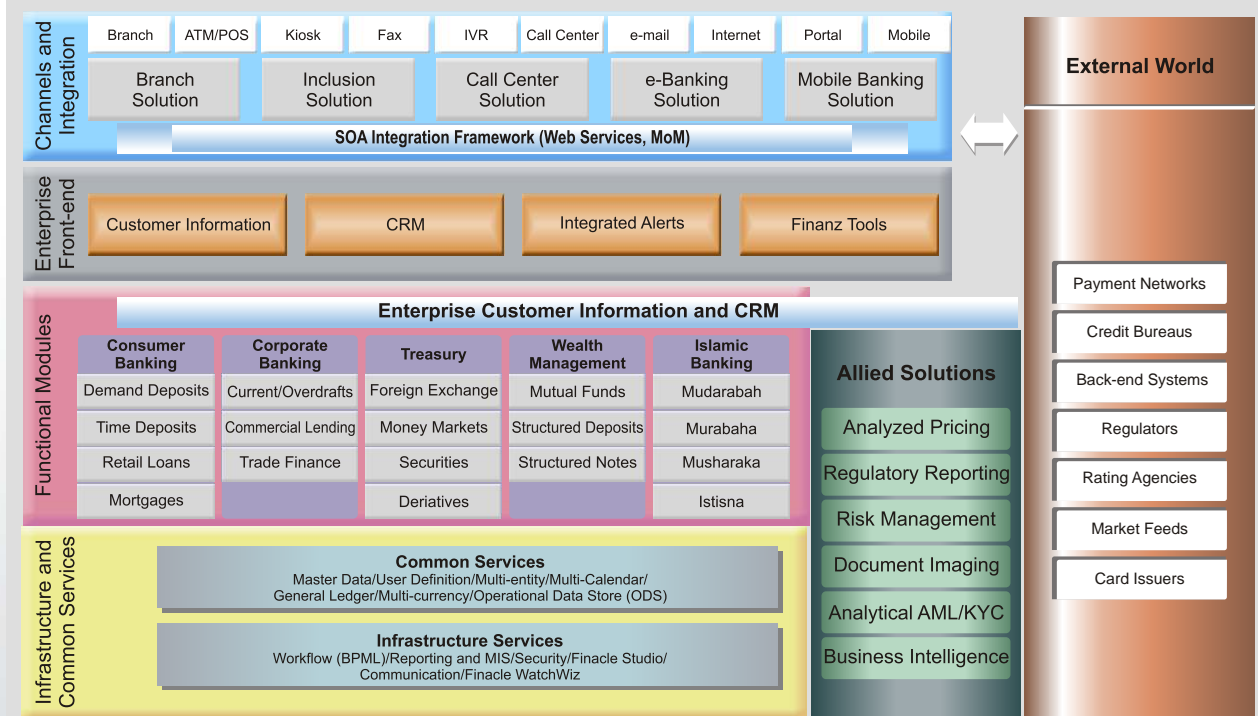

KEY MODULES



The mobility offering from Finacle is a logical extension of its proven Internet banking solution. All of Finacle's online capabilities can be translated to the mobile channel, with reduced lead times, ensuring rapid time-to-market for banks.

Customer On-boarding

Finacle enables the bank's existing customers to be directed to use the mobile channel for banking and payment transactions through the following modes:

- Phone banking leveraging the bank's telebanking call center
- Mobile banking facility requested by sending SMS request in prescribed format
- Registering for mobile banking through the bank's Internet banking site

The various flavors of mobile banking are:

- Browser-based mobile banking
- Downloadable-client based mobile banking
- Manual SMS banking

Finacle offers various functionalities for consumer and corporate banking leveraging GPRS or WAP-based transmission. An indicative list of features is:

- Account management and requests
- Local payments, bill payments and transfers
- Transaction approvals for corporate customers
- Merchant payments and reversals for POS, telephonic or internet-based purchase transactions
- Support for administrative tasks like secure mails to relationship manager, approvals, password change, data synchronization and self-audit

Mobile Commerce

Finacle offers commerce capabilities on its mobility and Internet platforms. Merchants and consumers can leverage Finacle mobile banking solution to perform business transactions at points of sale, with support for mobile and/or Internet banking. The solution offers out-of-the-box support for both merchant and customer initiated payments and reversals. Finacle mobile banking solution can service both retail and corporate consumers including the SME customer segment of banks.

Alerts

This module empowers customers to subscribe and receive alerts on multiple channels such as e-mail, SMS, voice, fax and Internet. It enables the customer to subscribe to alerts and choose a delivery channel. The module also allows the customer to set preferences for alerts and configure 'do not disturb' timings. The module supports the following:

- Personalized alerts
- Alerts from multiple back-end systems
- Batch or real-time alerts
- Alerts digest



BUSINESS BENEFITS

Robust Inclusivity Framework

Finacle mobile banking solution leverages Infosys MConnect to smoothly hurdle the challenges posed by the multiplicity of form factors and access mechanisms on multiple devices to provide a context-adaptable view to the transaction server. This enables banks to include, through the mobile channel, its various customer segments, ranging from the HNWI to specific unbanked communities, surmounting the complexities of diverse location and dissimilar mobile devices.

Maximize Innovation

Banks can leverage Finacle mobile banking solution's indigenously developed middleware Infosys MConnect, to configure an unlimited palette of services from any channel, to the mobile space, with ease. The need for development of new back end services is precluded due to the availability of a banking solution behind the mobile interface. Finacle also provides the flexibility to deploy services over the existing online banking platform or through a standalone delivery channel interfaced directly with the relevant host systems. This ensures the rapid delivery of a comprehensive range of financial services, embellished with new innovative features, on mobile devices.

Robust Security

The solution offers extensive application security features like URL encryption, referral URL check and session management to provide a robust security framework. The solution also supports OTP (one time password - MobiToken), which provides a two factor authentication mechanism for users transacting with downloadable mobility client. This enables the bank to offer products that are highly secure and geared to withstand the onslaught of security threats associated with mobile transactions.





Cost Savings

The solution presents banks with the advantages of reduced integration by leveraging common interface messages, maintenance and deployment costs. This translates into significant cost savings without banks having to compromise on features or the range of devices supported. The mobile banking solution is inherently independent of the network service provider, obviating the need to build a business model that involves costs and profits sharing with them.

Customer Delight

Finacle mobile banking solution enables banks to offer the convenience of

comprehensive anywhere anytime banking, using GPRS, WAP or SMS. It supports a wide range of mobile devices & mobile browsers. Banking customers can query on account balances and make fund transfers. Banks can also proactively send timely information to customers in a completely secure environment, whenever a customer-defined event occurs. The solution's self-service capabilities empower customers to manage their banking activities better. The solution also addresses data transmission and storage related security concerns adequately, delivering a truly streamlined customer experience.



USA/ LATAM / CARIBBEAN

Vikas Gupta

Tel.: +1 908 450 8220

Fax: +1 908 450 8201

SOUTH ASIA

Venkatramana G

Tel.: +91 98452 19809

Fax: +91 80 2852 1747

EMEA

Amit Dua

Tel.: +44 776 651 0099

Fax: +44 207 715 3301

APAC

South East Asia/Greater China/ Japan/Korea

Mahesh D K

Tel.: +91 98450 69004

Fax: +91 80 2852 1747

Australia/New Zealand

Shubhomoy Banerjee

Tel.: +61 400 954702

Fax: +61 3986 02999

e-mail: finaclemktg@infosys.com

www.infosys.com/finacle



Win in the flat world

Infosys Technologies Limited

Plot No. 44, Electronics City, Hosur Road, Bangalore - 560100. India
Tel.: + 91 80 2852 0261, Fax: + 91 80 2852 1747, e-mail: finaclemktg@infosys.com

© 2008 Infosys Technologies Limited, Bangalore, India. Finacle® is a registered trademark of Infosys and Infosys acknowledges the proprietary rights of the trademarks and product names of other companies mentioned in this document. Infosys believes the information in this publication is accurate as of its publication date; such information is subject to change without notice.